

Power & Signal Group Hand Crimp Tool User Manual



Power & Signal Group NA

4670 Richmond Road, Suite 120
Cleveland, OH 44128
USA
(216) 378-6600
(800) 722-5273
sales@powersignal.com

Power & Signal Group GmbH

Itterpark 9-11
40724 Hilden
Germany
+49 2103 250 0
saleseurope@powersignal.com

Power & Signal Group Asia

6/F Building 1
3000 Long Dong Avenue
Pudong, Shanghai 201023
China
+86 21 289 32000
salesasia@powersignal.com



Table of Contents

General hand crimp tool (HCT) information

- Introduction
- Function of HCT ratchet
- Scope of usage
- Responsibilities of user
- Note regarding HCT manual dimensions

HCT Power Assist Devices

Tool Types

- Tool Type 1: Blade & Box Terminals
- Tool Type 2: Pin & Sleeve Terminals

Assembly and Removal of HCT Die Sets

- Die selection
- Die insertion
- Die removal
- Crimp verification
- Crimp Height Adjustment

Crimp Tool Reference Data Sheet

Crimping Instructions

- Terminal Loading
- Terminal Crimping
- Crimp Height Measurement

Visual Crimp Quality Recommendations

- Good crimp
- Crimp dimensions not in tolerance
- Low core
- Insulation under core wing
- Twisted or distorted terminals or cable seals
- Excessive Tab
- All strands not captured by core wings
- Terminal straightness
- Cut or missing strands

HCT Maintenance & Cleaning

HCT Visual Inspection

Wire Stripper Instructions

HCT Support

General Hand Crimp Tool (HCT) information

Introduction

Power & Signal Group's HCTs have been designed to optimize crimp quality for low volume, repair, or prototype usage. In North America and Asia, the HCTs may be ordered as individual die sets. In Europe, the Middle East & Africa, the HCTs may be ordered pre-assembled or as individual components to crimp multiple Delphi Connection System terminals to various cable sizes. The HCT is sold in one of two designs, both ensuring optimum crimp quality. Type 2 crimps pin and sleeve terminals while Type 1 crimps blade and box terminals.

Function of HCT ratchet

The Power & Signal Group HCT ratchet has detents. There are six audible "clicks" from opening to closing. The crimp tool is designed to complete the full cycle of detents in order to assure a quality crimp.

If it is necessary to open the HCT prior to full closure, press the handles together slightly. Turn the emergency unlocking release clockwise (direction of the arrow) and open the handles simultaneously.

NOTE: If the emergency release is utilized, the crimped terminal is not to be used.

Scope of usage

Power & Signal Group Hand Crimp Tools (HCT) have been developed for optimal crimping in:

- Low volume production
- Repair
- Field Service
- Prototyping

The HCT should not be used for other purposes. Repetitive Stress Injury (RSI) can result from a prolonged use of manually powered hand crimp tools. Power & Signal Group hand crimp tools are intended for occasional and low volume applications only. Please call Power & Signal Group for availability of power applicator dies and equipment for high-volume applications.

Responsibilities of user

The operation, maintenance and service of the Power & Signal Group HCT requires a degree of practice and skill. Each person who is working with the HCT must be familiar with the tool's operation and follow the manual's instruction. Therefore, the instruction sheet must be constantly within reach of the HCT. In addition, any other instructions resulting from current national regulations in terms of health and safety should be maintained with the tool's instruction sheet.

The user shall not make any revisions to the HCT without the consent of the manufacturer or supplier.

Before using the HCT, the operator should conduct a visual inspection of the tool to verify that it is not damaged, maladjusted, or otherwise malfunctioning.

Power & Signal Group declines to accept any liability for damages that occur due to inappropriate use of the HCT or disregard for the guidelines set forth in the tool's instruction sheet.

The user of the HCT is responsible for the quality of the crimp.

Note Regarding HCT manual dimensions

Dimensions provided in this HCT Usage Manual are in millimeters (mm). Figures and illustrations are not drawn to scale.

HCT Power Assist Devices

Power & Signal Group can also recommend or, in limited instances, supply Pneumatic or Mechanical Assist devices for use with standard PSG Hand Crimp Tools. For more information, please contact the technical support group for your region.

Tool Types

Tool Type 1: Box & Blade Terminals

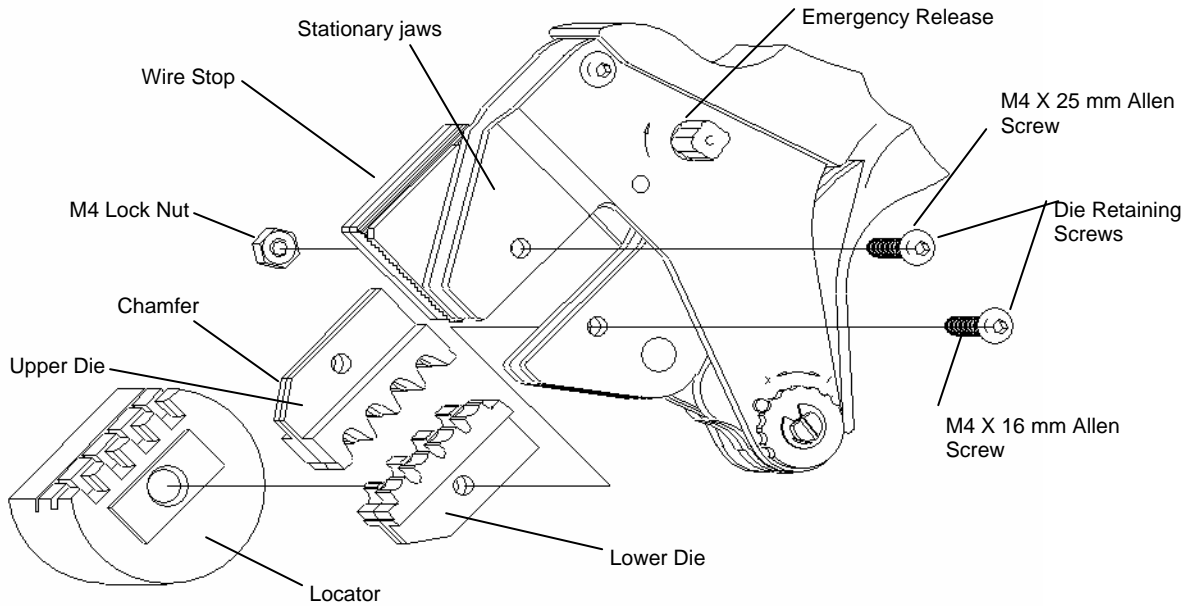

Tool Type 1 (Box & Blade Terminals)

Wire Stop: Do not over tighten the wire stop M4 nut. Make certain that the wire stop spring loaded blade moves freely up and down.

Die Set: Assemble allen screws, do not over tighten. Tighten screws after closing handles to fully seat the upper and lower dies.

Tool Type 2: (Pin & Sleeve Terminals)

Turn knurled knob to open and close wire stop/locator to hold terminal in place.

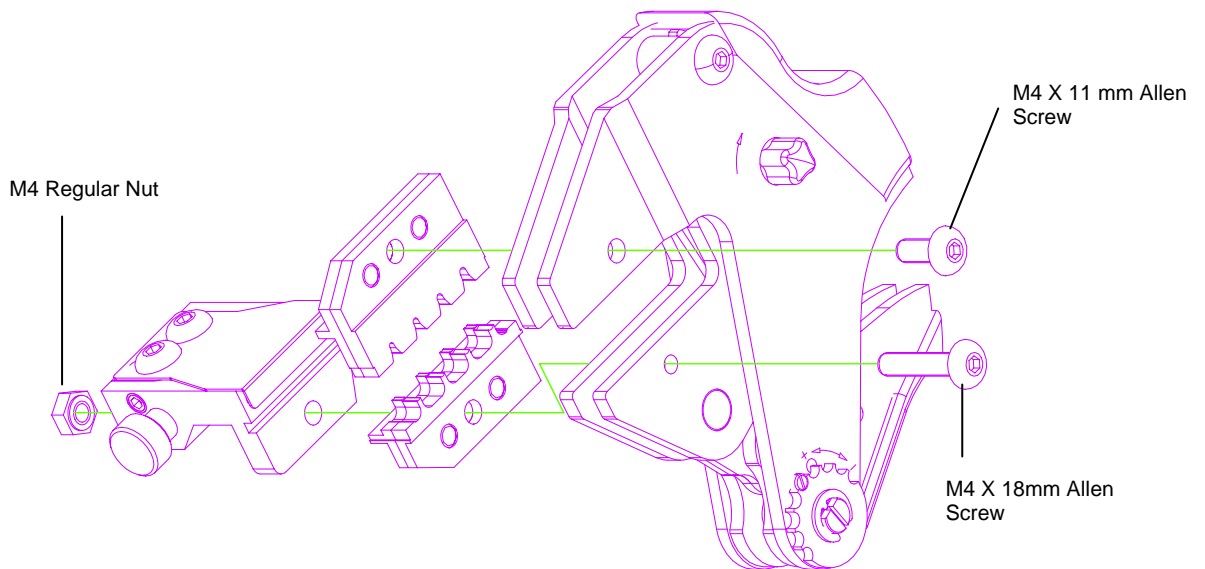

For All Tool Types

Place end of stripped wire against the wire stop.

Assembly and Removal of HCT Die Sets

If you have purchased a pre-assembled HCT begin with the crimp verification instructions.

Die selection

- Select the appropriate die for the terminal part and gauge size as defined in the Crimp Tool Reference Data Sheet.

Die insertion

- Assemble the upper and lower die inserts together with the terminal locator and wire stop.
- Be sure that the beveling side points to the left.
- The proper nut and allen screws are provided with each tool kit.

Die Removal

- Open the tool handles.
- Loosen and remove the two die retaining screws by means of an Allen wrench
- Slide the dies out of the tool jaws.

Crimp verification

In order to ensure proper crimping and to control the wearing of the tool and die, crimp verification must be done after every die set change and regularly thereafter.

Step One

Measure the crimp height and width with a caliper.



Step Two

Compare the caliper results to the specified tolerance range found in the Crimp Height Reference Data Sheet included with each die set.

If the crimp height is out of the specified tolerance range, the HCT needs to be adjusted.

Crimp Height Adjustment

- Remove set screw.
- Rotating the adjustment wheel counterclockwise increases the crimp force and decreases the crimp height.
- Rotating the adjustment wheel clockwise decreases the crimp force and increases the crimp height.
- Reinsert set screw

— Set screw (2-hole positions available)

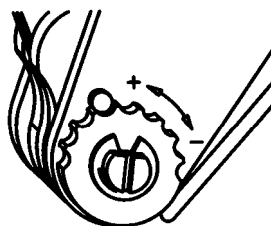

— Crimp Height Adjustment

Crimp Tool Reference Data Sheet

Power & Signal Group supplies specific required information with each shipment of its pre-assembled hand crimp tools and with individual die inserts. Information includes terminal part number, cable type, strip length, and other information relevant to obtaining a quality crimped terminal. Additional validation data is available upon request.

Crimping Instructions

The proper inserts, terminal locator and wire stop should always be used for the intended terminal and wire gauge size (See Crimp Tool Reference Data Sheet).

- Reference tool number, terminal name and wire gauge sizes on tool parts.
- Reference terminal part numbers and cable gauge sizes from authorized wiring prints or other documents.
- Use the specific cable strip length from the Crimp Tool Reference Data Sheet.

Terminal Loading

Insert loose piece terminal into holder opening as shown in Figure 1. Type 2 (Pin & Sleeve Terminal) locators must be opened with knurled wheel and closed to orient terminal so as to capture terminal wings. Use correct cable seal if required (Figure 2).

Figure 1



Figure 2

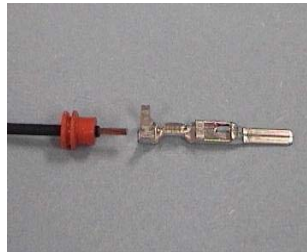

Make sure terminal is fully inserted so wings are over the crimp anvils. If wings do not catch properly, slightly bend inward to clear upper plate. Partially close ratchet handles to capture terminal. (Use wrench to turn square nut clockwise to release handles if terminal is not captured properly.)

Position stripped wire end against wire stop in bottom of crimp wings for Type 2 or in upper die for Type 1. *Make sure the spring loaded wire stop returns after each crimp.* (If wire stop does not return, the locking nut is too tight or the stop needs to be lubricated.) If a cable seal is used, make sure the seal is positioned so that the insulation wings capture the seal. Make sure no strands are cut or are missing in the stripping process.

Terminal Crimping

Complete the ratcheting closure of handles until they spring open. Remove crimped leads carefully.

Inspect crimped lead according to the Visual Crimp Quality Recommendations to eliminate non-conformances:

Measure all crimp dimensions with calibrated measuring equipment. Compare to crimp dimensions supplied with the tool inserts for specific cable size and terminal part number.

If crimps are too high, remove set screw and turn serrated wheel counterclockwise (+) until proper crimp height is achieved. (Reinsert screw before trying again.) If core crimp height is too tight, follow the same procedure except turn in a clockwise direction.

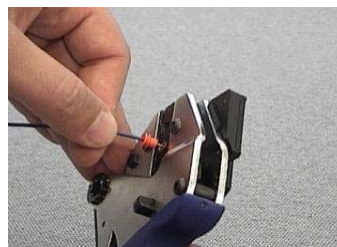

Crimp Height Measurements

In order to insure proper crimp quality, the crimp height must be measured and readjusted if it does not meet the Core Crimp Height (CCH) requirements as shown in the Crimp Tool Reference Data Sheet for the specified terminal and cable size. The CCH should be measured with approved calipers.

Visual Crimp Quality Recommendations

Good Crimp:



Correct crimp tool application will minimize or eliminate non-conforming crimps. Improperly crimped terminals may fail electrically. Practice on samples until good quality crimps are consistently made. Crimped terminals must always be 100% visually inspected after crimping process by following the non-conformance listings below.

Crimp dimensions not in tolerance:

CAB-SIZE	CAB-CODE	PRIMARY-STRIP		PULLTEST		
		CORE-CH	CORE-CW	INS-CH	INS-CW	
	TERMINAL P/N	12191811	GT 150 unsealed			
.35		142	5,1	65		
		1,05	1,75	2	2,1	

Wrong insert tooling, crimp adjustment not right, inserts not seated, wrong insert jaw, wrong cable or terminal (See data sheet with tooling.)

Low core:

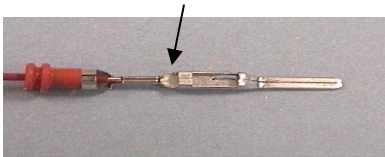

Core not showing in front of terminal core wings due to short strip, not using wire stop or incorrect placement.

Insulation under core wing:

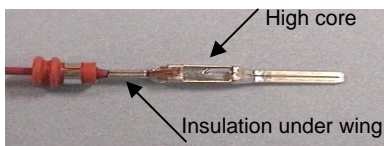

No strip, short strip, wire stop not used, incorrect placement (may also result in high core).

Twisted or distorted terminals or cable seals:



Terminal not positioned correctly in tool.

Excessive Tab



May damage seal or cause seal to not seal properly. Terminals not cut off strip properly.

All strands not captured by core wings:



May cause a loose crimp and electrical or mechanical non-conformance. May need to inspect strands prior to crimping.

Terminal straightness:

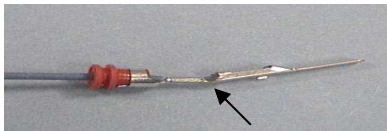

Excessively bent terminals may cause terminals not to seat, push mating terminal out of cavity, or not be able to seat Terminal Position Lock. May be caused by locating terminal incorrectly in tool.

Cut or missing strands:

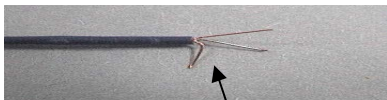

Incorrect stripping of cable. May cause a loose crimp and electrical or mechanical non-conformance.

HCT Maintenance and Cleaning

Responsible personnel and operators of the Power & Signal Group HCT should maintain the tool with each use.

- Use a clean, lint-free cloth to remove dust, moisture, and debris from the tool. Do not use abrasive cleaners on the tool, which could result in damage.
- Make sure that all screws and other removable parts are secure and in place.
- All pivot points, bearing surfaces, joints, and other movement points should be regularly oiled.
- When the tool is not in use, its handles should be closed to prevent foreign objects from being lodged in the niches and recesses of the tool.
- Store the tool in a clean and dry area.

HCT Visual Inspection

- Quality control personnel should regularly check up on the HCT to ensure that crimp quality is optimal.
- Inspections on the tool should be made regularly and logged.
- The frequency of use, working environment, company standards, and operator training, strength, and proficiency are some factors to take into consideration when inspecting the tool.
- When visually inspecting the tool, grease should be removed by using a commercial degreaser that will not negatively affect the tool.
- After the tool has been degreased, make sure that the range of motion on the tool is quick and clean when you open and close the tool.
- Inspect that the wire stop, holders, jaws, and other moving parts are in place.
- Make sure that the unit is not missing any screws and that the emergency release is operational.
- If there is any damage spotted, make sure it is noted and properly cared for. If the tool is still in useable conditions, then lubricate the tool and return to service. Do not use excessive amounts of oil.
- If any adjustments or replacements need to be made, please contact the Power & Signal Group service number for your region.

Wire Stripper Instructions

Obtain the proper strip length from the Crimp Tool Reference Data Sheet, which is listed for each cable gauge size of the specified terminal part number. (Wire Strippers are not included with all HCTs)

- Adjust the red wire stop on the stripper to the proper strip length.
- Inspect the stripped leads carefully for cuts, scrapes, missing strands or deformed insulation in the strip area.
- Readjust wire stripper if necessary.
- A complete visual inspection is recommended prior to crimping.

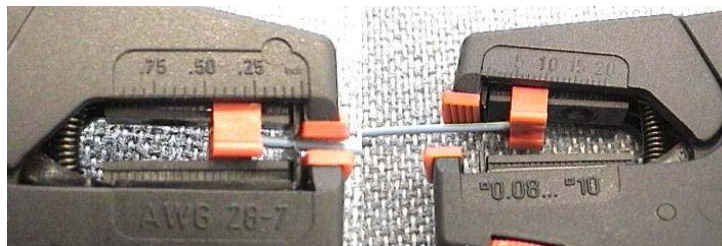

Imperial scale (inches)
(for wire gauge 28-7)

Metric scale (mm)
(for wire gauge 0.08-10)

HCT Technical Support

For assistance, please contact:

Power & Signal Group NA
4670 Richmond Road, Suite 120
Cleveland, OH 44128 USA
Engineering Tech Line: (800) 610-4837 or (216) 378-6600 ext. 5422
Sales: (800) 722-5273 or (216) 378-6600 or sales@powersignal.com

Power & Signal Group EMEA
Itterpark 9-11
40724 Hilden Germany
Engineering Tech Line: +49 2103 250 510
Sales: +49 2103 250 0 or saleseurope@powersignal.com

Power & Signal Group Asia
6/F Building 1
3000 Long Dong Avenue
Pudong, Shanghai 201023 China
Sales: +86 21 289 32000 or salesasia@powersignal.com